

ERBESSD INSTRUMENTS®

PHANTOM

WIRELESS MACHINE SURVEILLANCE

Machine Health Monitoring Solutions



Wireless Technology

Phantom is the best all-inclusive battery powered wireless machine monitoring system worldwide.

Phantom's exclusive technology enables full frequency range diagnosis just like ICP Accelerometers.

General Info

Accelerometers

Triaxial + Temperature
10 kHz FMax
Full waveform and spectrum data
Programmable Internal RMS Trigger
Maximum 6400 Lines of Resolution

Amperage

3 phases
5 - 1000 Amps

RPM

Rotation speed
200'000 RPM

Temperature

Thermocouple
Infrared Non Contact Sensor

General Purpose Input sensor

For proximity sensors or any other device
2 simultaneous channels
Orbits capability
48,000 Hz Sample Rate

Cloud or Local Network Capability with Open SQL Database

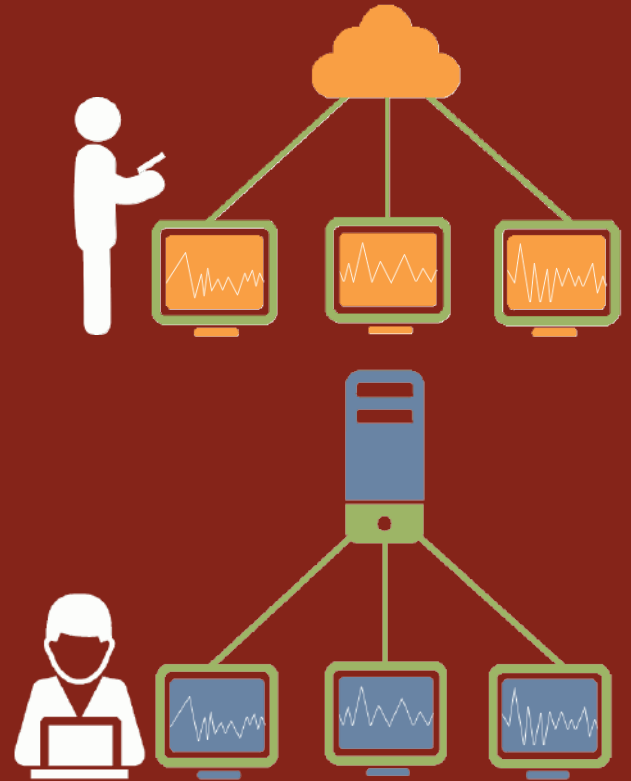

Storage

The Freedom to Choose:

- » Store data locally
or
- » Store data on the Cloud
(Open SQL database)

IT'S YOUR DATA: All data can be accessed through any database API for SQL or MySQL.

Experience the **power of DigivibeMX** software with Phantom.

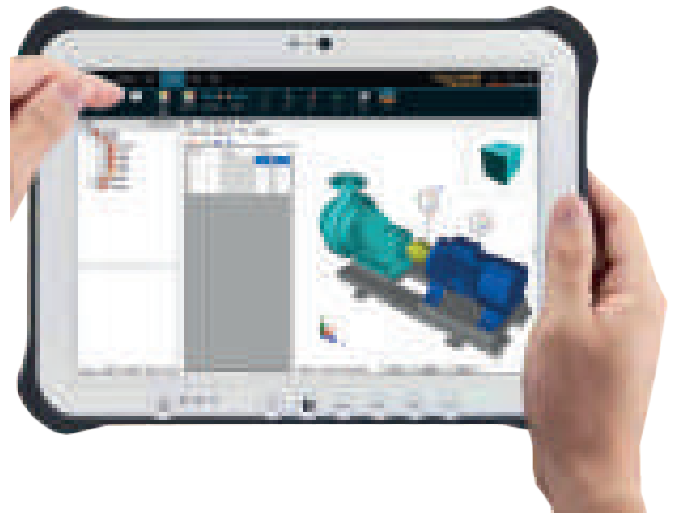

- » Autodiagnostic tools
- » Trending & Octave Bands
- » 3D views and Simulations
- » Automatic reports
- » 3D Waterfall
- » Phase Analysis
- » Envelope Alarms
- » 30,000+ bearings database
- » And MUCH MORE...



Mobile SmartAlert™ Technology is here

Trending & Octave Bands

Vibration Trending is a useful function to track the condition of your machines.

Octave bands trending is by far more powerful because it tracks every frequency by dividing the full spectrum into 32 bands and tracks the RMS value of each one of the bands independently helping to identify a change in amplitude easily.

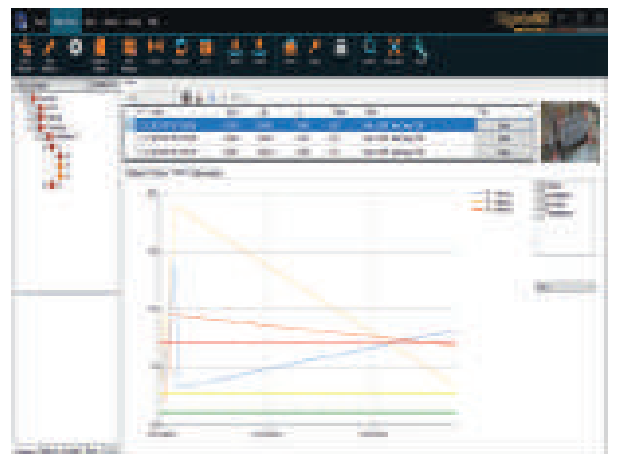

Trending
Software DigivibeMX

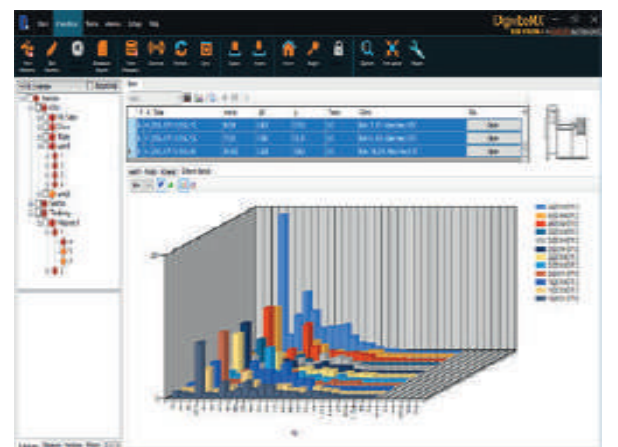

Octave Bands
Software DigivibeMX

5

Monitoring Modules

Sensor Type	Triaxial Accelerometer
Sensor Range	8 / 16 / 32 g
Sensor Accuracy	± 3db
Sensor freq. range	10 kHz (x, y) 5.1 kHz (z)
Sampling Rate	25600 Hz

Floor noise V122	XY: 0.12 mg/√Hz Z: 0.2 mg/√Hz
Floor noise V222	XY: 0.63 mg/√Hz Z: 0.9 mg/√Hz
Internal Temperature Accuracy	± 1 °C (± 1.8 °F)
Operating Temperatures	-40 to 85 °C (-40 a 185°F)
Storage Temperatures	-60 to 105 °C (-76 a 221°F)
Size	47mm x 33 mm (1.85 x 1.3 in)
Weight	100 grams / 3.5 oz

Battery type	3.6 V Li – TL-5935
Battery Life	2 - 4 years
Transmission Type	2.4 GHz BLE 5.0
Distance Range	150m, Line of Sight
Distance w/ Repeaters	Unlimited
IP Rating	IP67



Sensor Type	Tachometer
Switching Speed	Up to 10 KHz
RPM Range	0 – 200,000 RPM
Sensor GAP	1 - 15 mm
Sensor Type	Hall Effect - Omnipolar

Magnet Type	Neodymium
Operating Temperature	-40 to 85 °C (-40 to 185 °F)
Storage Temperature	-60 to 105 °C (-76 to 221 °F)
Size	47mm x 39 mm (1.85 x 1.53 in)
Weight	100 grams / 3.5 oz
Battery type	3.6 V Li – TL-5935

Battery Life	5-9 years
Transmission Type	2.4 GHz BLE 5.0
Distance Range	150m, Line of Sight
Distance w/ Repeaters	Unlimited
Included	Hall Effect Sensor
IP Rating	IP67

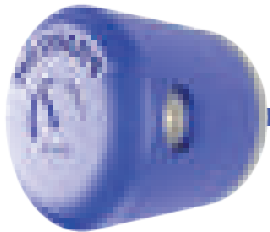

Sensor Type	Temperature (Thermocouple)
Sensor Accuracy	0.15 %
Sensor Range	-210 °C – 1800 °C
Thermocouples Types	K/J/N/R/S/T/E/B
Resolution	0.25 °C (0.45 °F)

Max. Wire Length	25 m.
Operating Temperature	-40 to 85 °C (-40 to 185 °F)
Storage Temperature	-60 to 105 °C (-76 to 221 °F)

Size	47mm x 39 mm (1.85 x 1.53 in)
Weight	100 grams / 3.5 oz
Battery type	3.6 V Li – TL-5935
Battery Life	5-9 years

Transmission Type	2.4 GHz BLE 5.0
Distance Range	150m, Line of Sight
Distance w/ Repeaters	Unlimited
Included	Type K Thermocouple
IP Rating	IP67



Sensor Type	General Purpose Input
Input Range	± 3 Volts / ± 24 Volts
Amplitude range	24 bits – 108 dB
Channels	2 (simultaneous)
Sampling Rate	44100 Hz

Internal Temperature Accuracy	± 1 °C (± 1.8 °F)
Operating Temperatures	-40 to 85 °C (-40 to 185 °F)
Storage Temperatures	-60 to 105 °C (-76 to 221 °F)
Size	47mm x 39 mm (1.85 x 1.53 in)
Weight	100 grams / 3.5 oz
Battery type	3.6 V Li – TL-5935

Battery Life	2 - 4 years
Transmission Type	2.4 GHz BLE 5.0
Distance Range	150m, Line of Sight
Distance w/ Repeaters	Unlimited
Included	Cable adapter
IP Rating	IP67

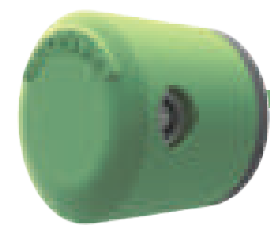

Sensor Type	Current – 3 Phases
Sensor Range	50 / 150 / 500 / 1000 A
Frequency	50 / 60 Hz up to 400 Hz
Sensor Accuracy	± 0.5 / ± 1.5 / ± 1 / ± 1 %

Operating Temperature	-40 to 85 °C (-40 to 185 °F)
Storage Temperature	-60 to 105 °C (-76 to 221 °F)
Size	47mm x 39 mm (1.85 x 1.53 in)
Weight	100 grams / 3.5 oz
Battery type	3.6 V Li – TL-5935
Battery Life	5-9 years

Transmission Type	2.4 GHz BLE 5.0
Distance Range	150m, Line of Sight
Distance w/ Repeaters	Unlimited
Included	Non invasive current sensor
IP Rating	IP67



Easy to install
Ultra long
battery life



Small & intelligent

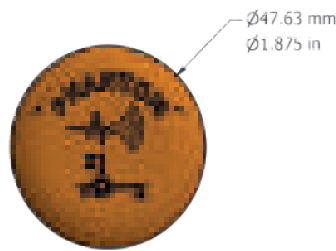
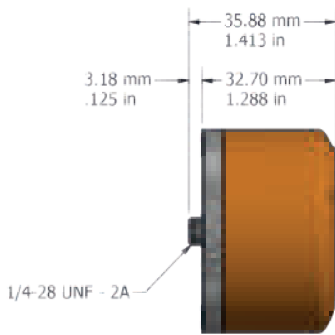

Module Design

- » IP67 Dust & Water Proof
- » MIL-SPEC 810G Rugged
- » Easy 1/4 28" Thread Installation
- » Automatic reports
- » Network Programmable

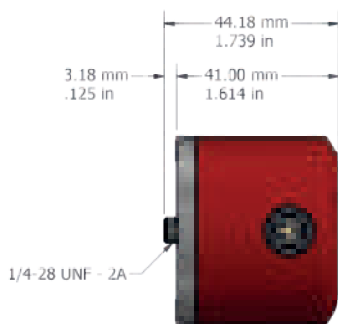

Gateway

Wifi, 4G & Ethernet capable, LCD status screen



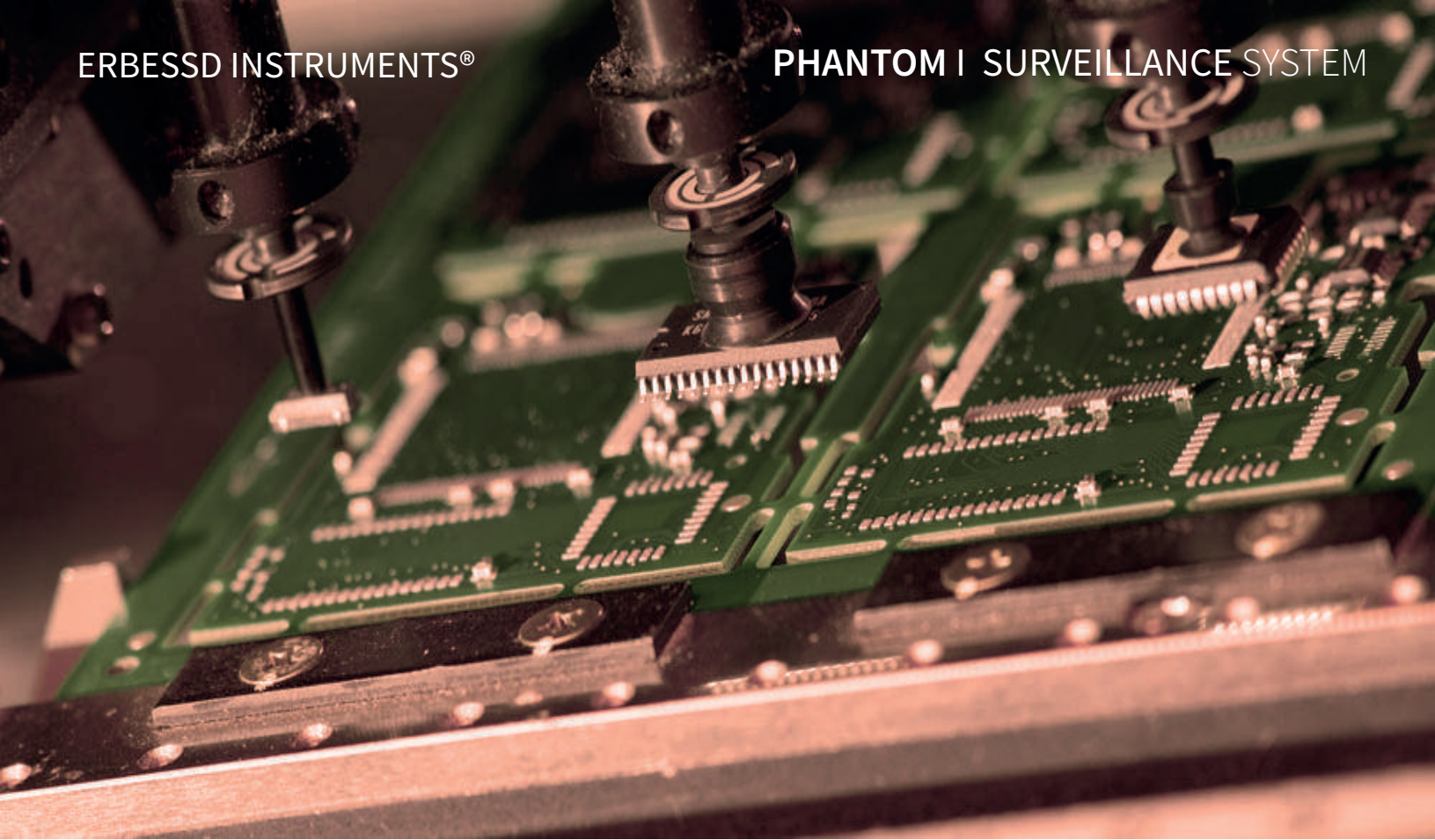

Not all wireless is created equal.

Never compromise your data acquisition needs based on poor battery life, low fMax, or high noise floor technology.

Phantom's BLE technology guarantees optimal life and system performance.

No Wires...
No People...
No Hazards...
Less Worries...
Why Wireless?

kit Includes:



Phantom
(12 pieces)



1 Gateway

ERBESSD INSTRUMENTS®

WORLDWIDE toll-free:

+1-877-223-4606

ENGLISH:

Sales, Service & Support Engineer

+1-518-874-2700

info@erbessdreliability.com

SPANISH & FRENCH:

Sales, Service & Support Engineer

+52 (55) 6280-7654 / +52 (999) 469-1603

info@erbessd-instruments.com

BUY ONLINE

www.erbessd-instruments.com

ALL THE IMAGES ARE FOR ILLUSTRATIVE PURPOSES ONLY. THE FINAL PRODUCT MAY VARY DEPENDING ON THE VERSION AND/OR THE CHANGES OR UPGRADES MADE TO THE PARTS AND COMPONENTS OF THE DEVICES

© 2018 ERBESSD INSTRUMENTS LLC